

TECNIS 173 table light/twin

Desktop-Monitor



TECNIS



„visulutionary“

['vɪʒu'lu:ʒənəri] ADJ:

describes the feeling and impression
you get when you use unique integrated
monitor solutions from ELEMENT ONE™.

TECNIS 173 table light/twin

Desktop-Monitor



“What is TECNIS?”

The TECNIS Table Light is a desktop monitor & a design piece for discussion. Whether as a stand alone device on your desk or as a complement to built-in electromechanical CONVERS, MODIS, VERSIS or ROTATIS in the communication space:
The TECNIS table light is an eye-catcher in the truest sense of the word.

A design first & fully customisable.
Compact & easy to bring into room design.

MADE IN GERMANY.
More than 15 years know-how in monitor-design.

Warranty 5 years mechanics,
2 years electric and electronic,
10 years spare part availability.

Sleek. Silent. Svelte.
Handcrafted & tested to ensure the highest standards.
Reliable partner with solid repeat business across diverse client fields. Global references and project experiences.

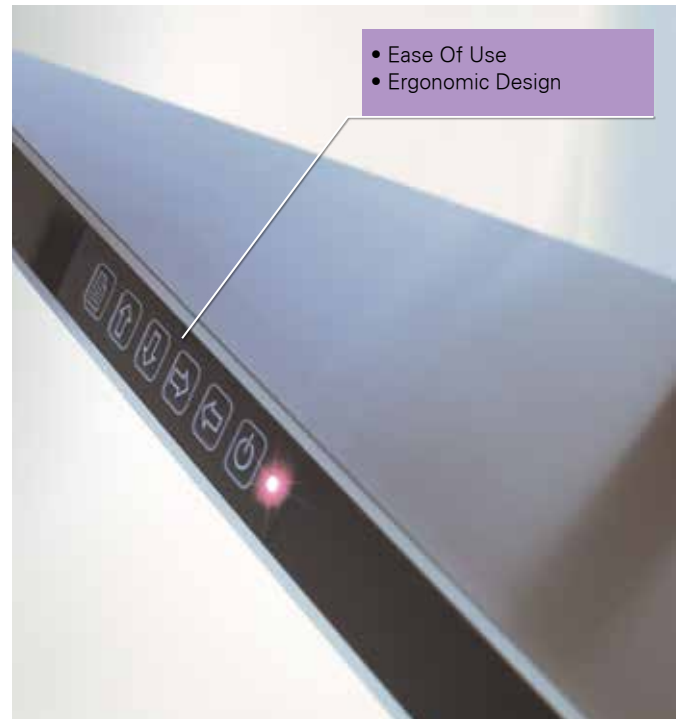

- Ease Of Use
- Ergonomic Design

GENERAL SPECIFICATIONS

Functionality	17,3" Desktop-Monitor (no electromechanics).
Motor & Mechanics	Angled Footplate
Material	Monitor - Aluminium silver anodized & 3 mm protective antireflective glass Trim - Black Acrylic glass decorative inlay Footplate - Powder coated black
Dimensions	440 x 365 x 202 mm (with base)
Mass	4,6 kg
Inclination	fix 15°
Height (lifted)	fix 36,5 cm
Monitor	Full HD 17,3" LED TFT HDCP compliant Active Matrix Widescreen Format
Brightness	400 cd/m ²
Contrast Ratio	600:1
Resolution	1920 x 1080 – Full HD (16:9), 16.7M Colors
Pixel Size	0.1989 x 0.1989 mm
Viewing Angle	Horizontal 160°/Vertical 140°

Viewing Area	381.888 (h) x 214.812 (v) mm
LED Lifetime	up to 50.000 hrs
Video Interface	HDMI, VGA Optional
Remote Control	-
Power Consumption	15W
Certificates	TÜV, CE, FCC
Warranty	5 years extendable (optional, surcharge) spare part availability 10 years

SCOPE OF SUPPLY

Power adapter - Input: 100-240 V~, 50/60Hz. 1.5 A;
Output: 12 V 5.A 60W MAX

(cable length: DC ~140 cm; AC ~ 1,5 m)

AVAILABLE OPTIONS

Custom color - Anodization or powder coating
Custom color and -material decorative trim
Print customized logo
Multitouch overlay
Double - Full HD Camera

TECNIS 173 table light/twin

Desktop-Monitor



- Sleek ELEMENT ONE Design
- Material: Aluminum, Glass, Stainless Steel

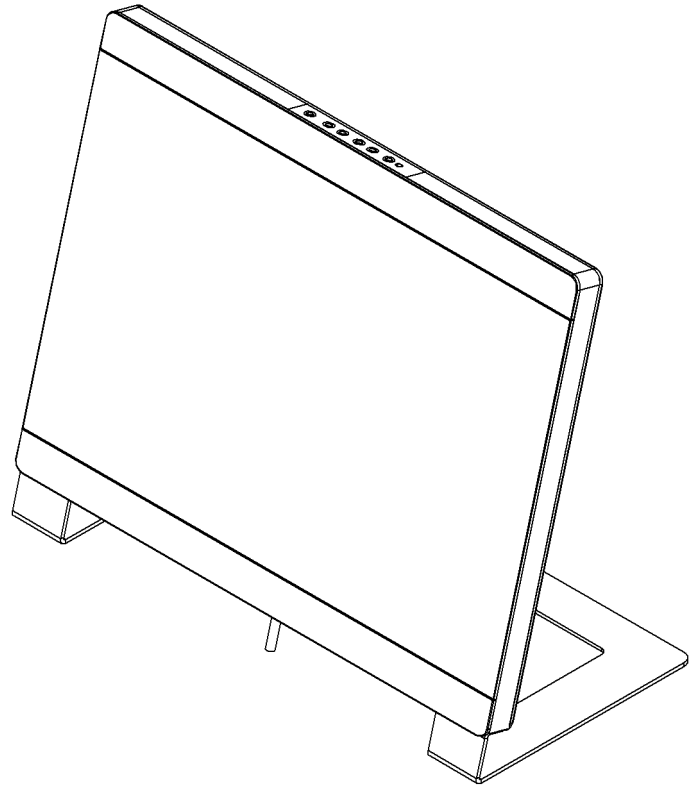

- Twin version with 880 mm widescreen

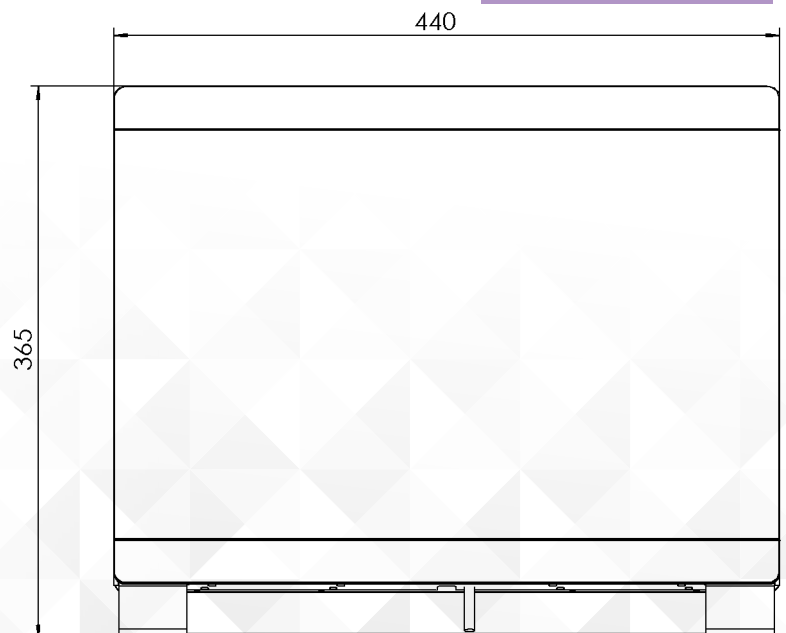
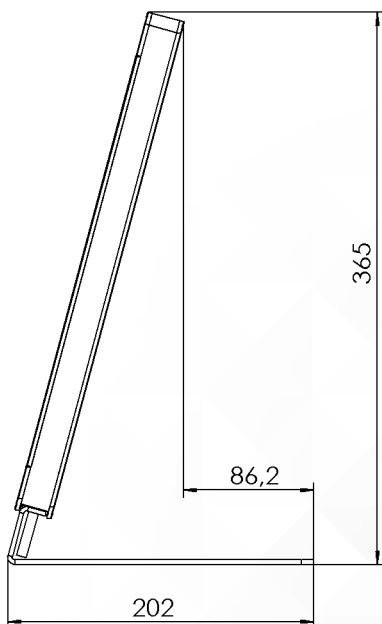

TECNIS 173 table light/twin

Desktop-Monitor



TECNIS

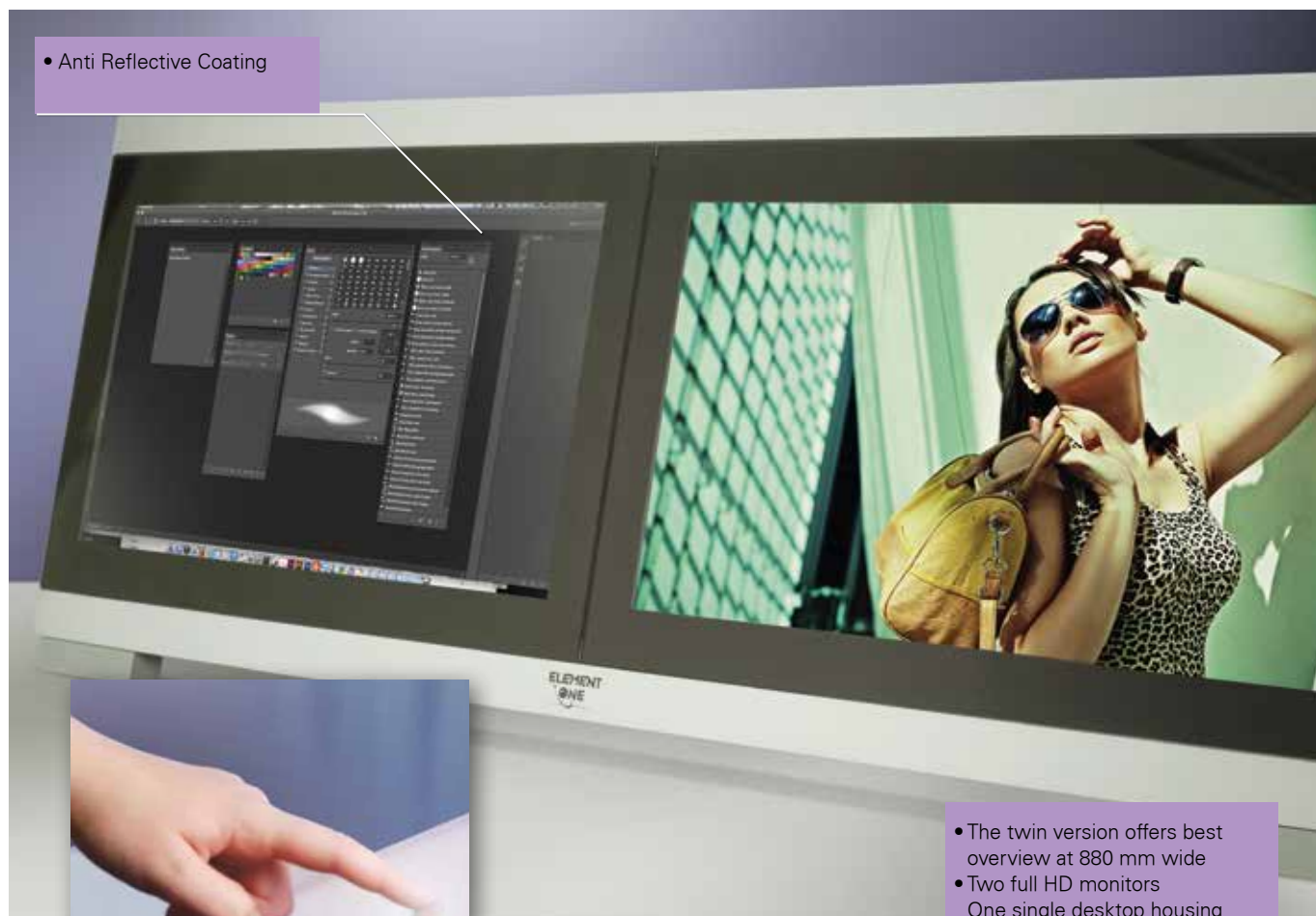

• Anti Reflective Coating



• Touchscreen - optional

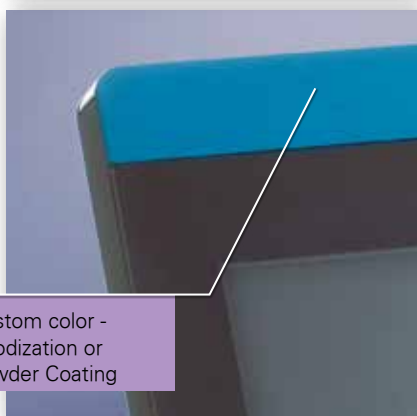

• Custom color - Anodization or Powder Coating

- The twin version offers best overview at 880 mm wide
- Two full HD monitors
- One single desktop housing
- Mounting kit for direct fixing (without feet) Table top - optional

Applications

Meeting
Lounge
Retail & Banking
Museum
Home Office

ELEMENT ONE Multimedia GmbH
Zum Murgdamm 5
D-76456 Kuppenheim
Germany
fon +49 (0) 7222 96654-0
fax +49 (0) 7222 96654-29
www.elementonescreens.com
info@elementonescreens.com